

Alpha Systems AOA Eagle Dual Pressurized Above Dash HUD System Diagram DSTR-AOA-9600DPK-(ADH)

Displays:
 Eagle Displays, P/N DSTR-AOA-9600
 Eagle Display, P/N DSTR-AOA-9600S

DRAWINGS NOT TO SCALE

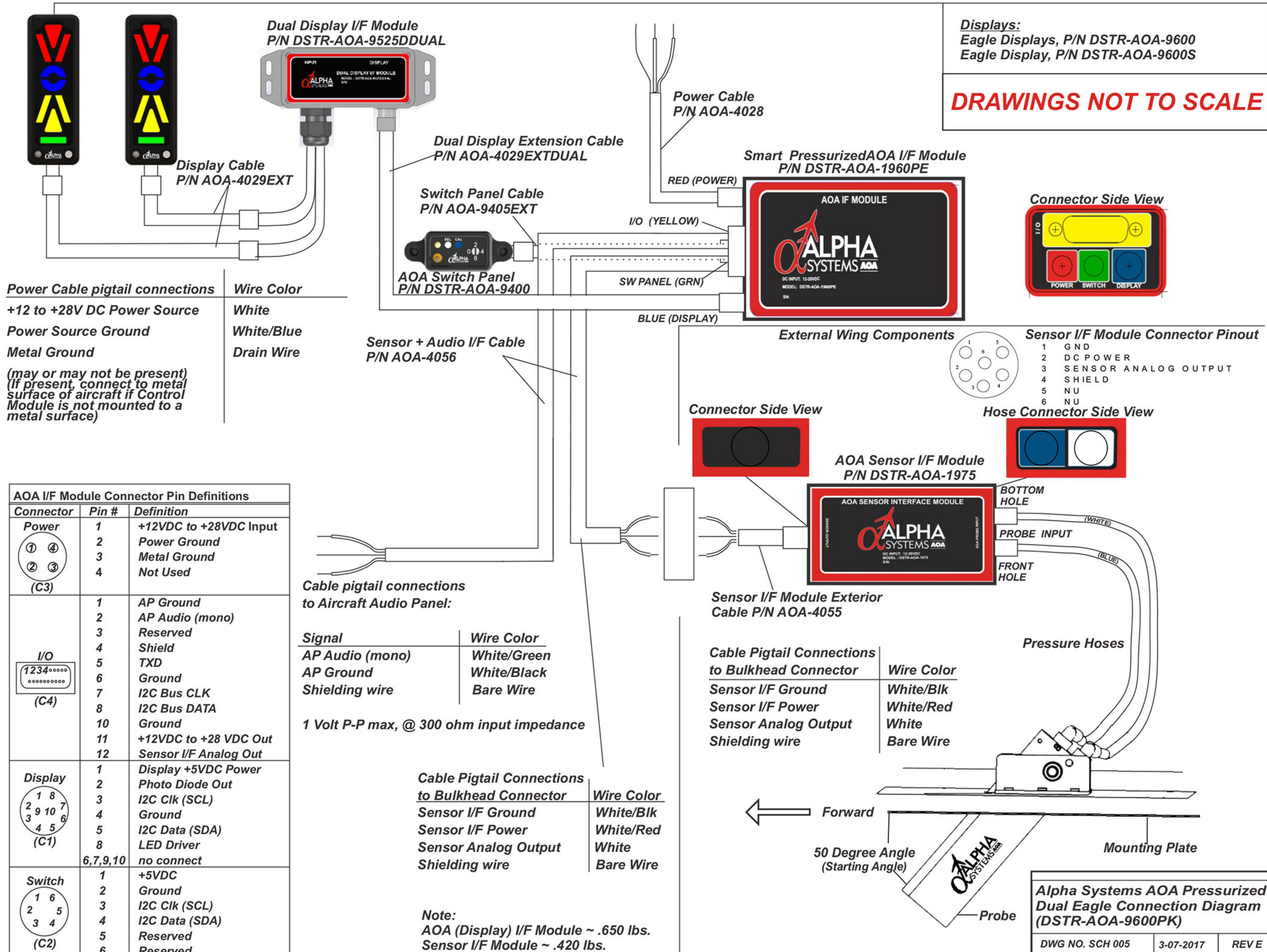

Power Cable pigtail connections	Wire Color
+12 to +28V DC Power Source	White
Power Source Ground	White/Blue
Metal Ground	Drain Wire

(may or may not be present)
 (If present, connect to metal surface of aircraft if Control Module is not mounted to a metal surface)

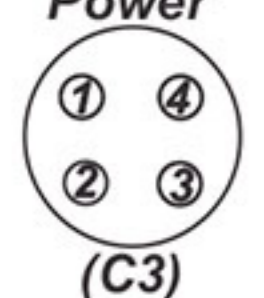
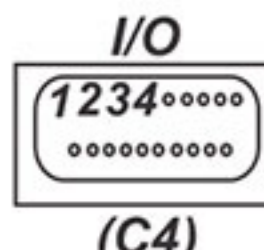
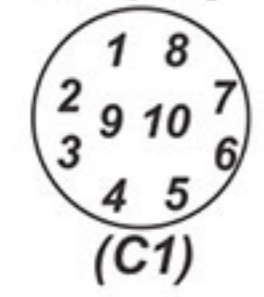
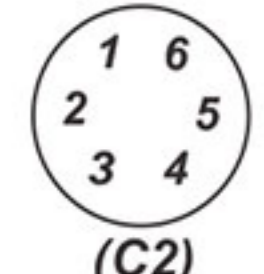
AOA I/F Module Connector Pin Definitions		
Connector	Pin #	Definition
 (C3)	1	+12VDC to +28VDC Input
	2	Power Ground
	3	Metal Ground
	4	Not Used
 (C4)	1	AP Ground
	2	AP Audio (mono)
	3	Reserved
	4	Shield
	5	TXD
	6	Ground
	7	I2C Bus CLK
	8	I2C Bus DATA
	10	Ground
	11	+12VDC to +28 VDC Out
	12	Sensor I/F Analog Out
	 (C1)	1
2		Photo Diode Out
3		I2C Clk (SCL)
4		Ground
5		I2C Data (SDA)
8		LED Driver
6,7,9,10		no connect
 (C2)		1
	2	Ground
	3	I2C Clk (SCL)
	4	I2C Data (SDA)
	5	Reserved
	6	Reserved

Cable pigtail connections to Aircraft Audio Panel:

Signal	Wire Color
AP Audio (mono)	White/Green
AP Ground	White/Black
Shielding wire	Bare Wire

1 Volt P-P max, @ 300 ohm input impedance

Cable Pigtail Connections to Bulkhead Connector

Wire Color	
Sensor I/F Ground	White/Blk
Sensor I/F Power	White/Red
Sensor Analog Output	White
Shielding wire	Bare Wire

Note:
 AOA (Display) I/F Module ~ .650 lbs.
 Sensor I/F Module ~ .420 lbs.

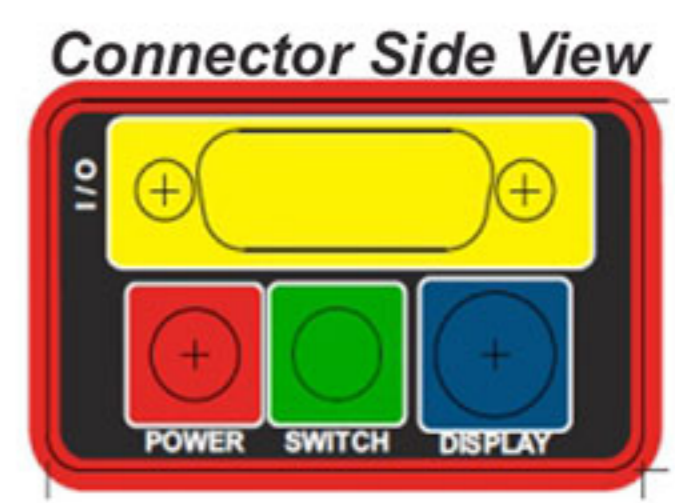

Sensor I/F Module Connector Pinout

1	GND
2	DC POWER
3	SENSOR ANALOG OUTPUT
4	SHIELD
5	NU
6	NU

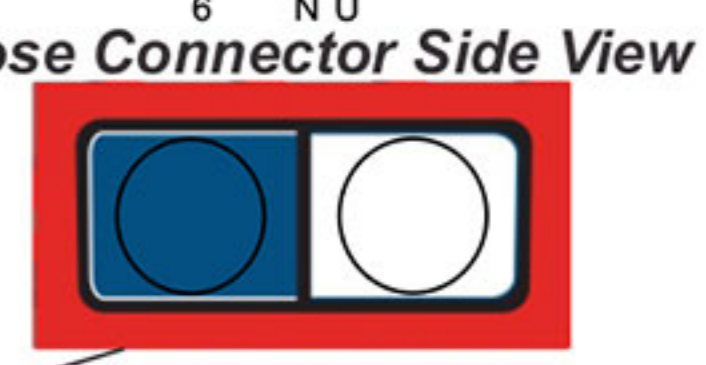
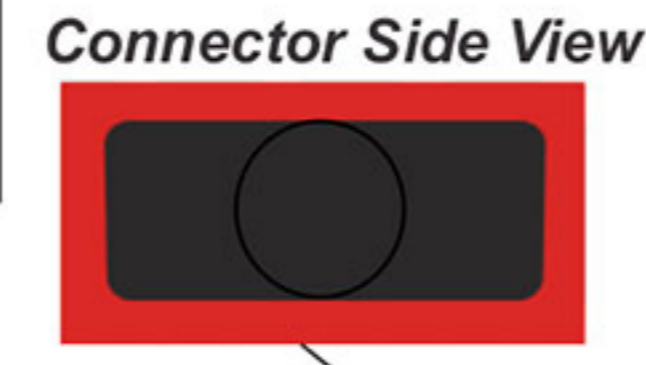

Cable Pigtail Connections to Bulkhead Connector

Wire Color	
Sensor I/F Ground	White/Blk
Sensor I/F Power	White/Red
Sensor Analog Output	White
Shielding wire	Bare Wire

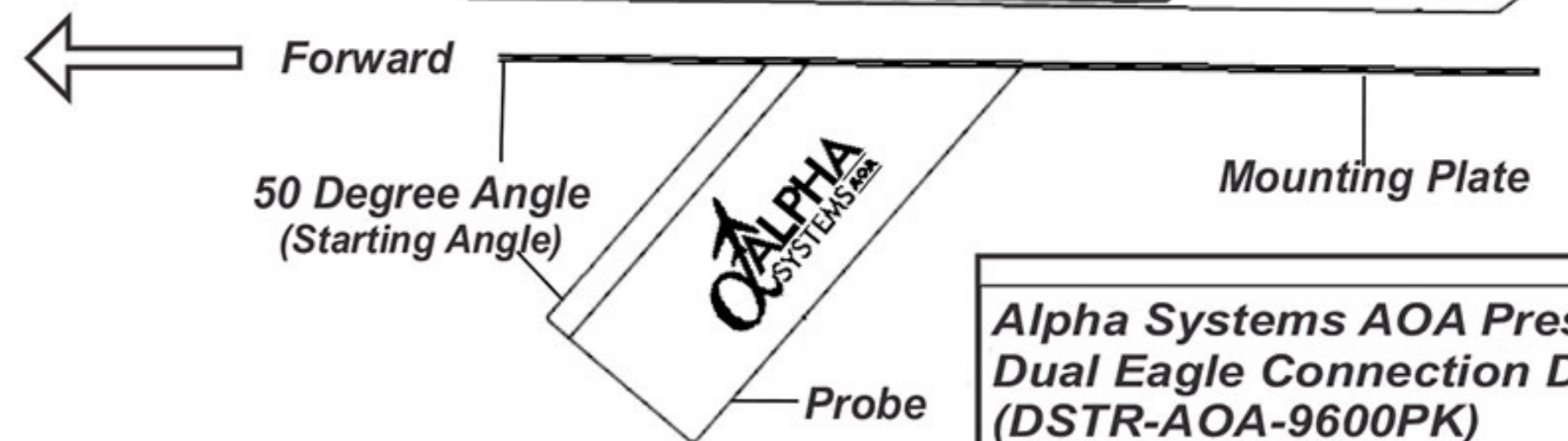

Alpha Systems AOA Pressurized Dual Eagle Connection Diagram (DSTR-AOA-9600PK)

DWG NO. SCH 005	3-07-2017	REV E
-----------------	-----------	-------